

ECN NO.	REV	DATE	DESCRIPTION	APP'D
	A0	20120325	drawing release	kevin

Specification:

1. Rating : DC 30V 0.5A;
2. Contact resistance: $\leq 30m\Omega$;
After life test: $\leq 50m\Omega$
3. Insulation resistance: $\geq 100M\Omega$ (500VDC);
After life test: $\geq 50M\Omega$
4. Withstand voltage: 500VAC ;
5. Insertion and extraction force: 5N~35N;
6. life test: 5000cycles min;
7. Operation temperature range: -20°C~70°C
8. Preservative temperature range: -40°C~85°C
9. Sign"▲" is importance dimension

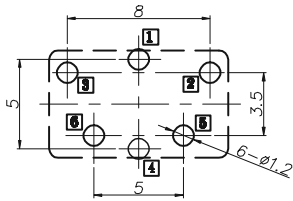
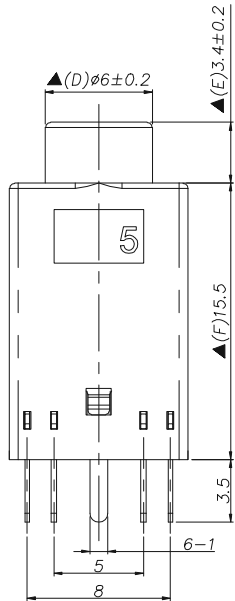
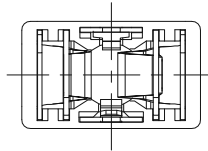
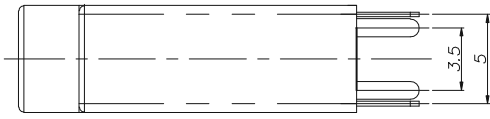
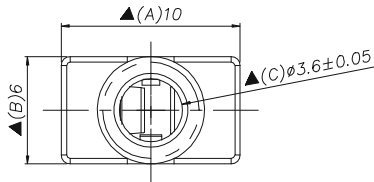

RECOMMENDED P. C. B. LAYOUT
UNSPECIFIED TOLERANCE: ± 0.05
(Copper-sided view)

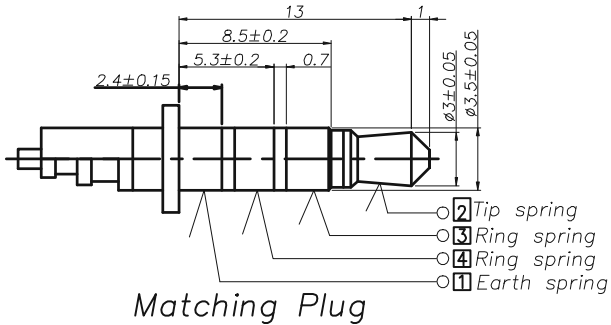
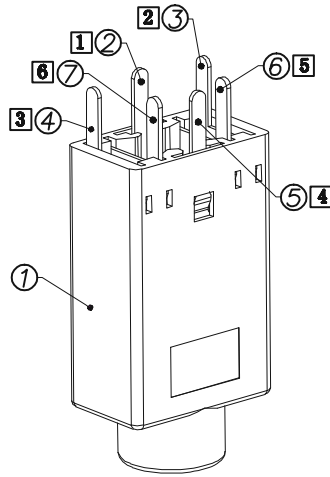

⑦	Shunt terminal	6	1	Brass 0.3t	06	Silver plating
⑥	Shunt terminal	5	1	Brass 0.3t	05	Silver plating
⑤	Ring spring	4	1	Phosphor bronze 0.25t	04	Silver plating
④	Ring spring	3	1	Phosphor bronze 0.25t	03	Silver plating
③	Tip spring	2	1	Phosphor bronze 0.25t	02	Silver plating
②	Earth spring	1	1	Phosphor bronze 0.25t	01	Silver plating
①	Housing		1	PBT,UL-94V-0	S1	
ITEM	DESCRIPTION	QTY	MATERIAL	PART NO.	REMARK	

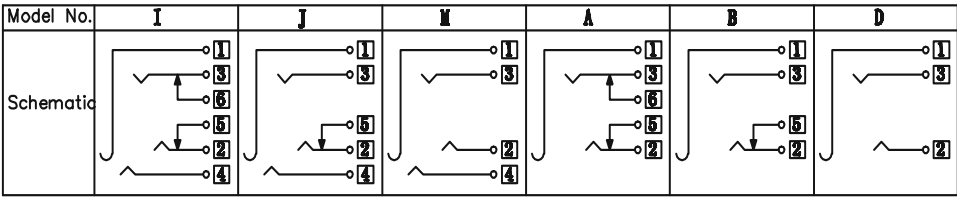

□: TERMINAL NO.

LINEAR	ANGLE	NAME (INTENDED USE) PHONE JACK	东莞市全晟通精密制造有限公司 DONGGUAN QUAN SHENG TONG PRECISION MANUFACTURING CO. LTD			
± 0.25	± 2	PART NO. (INTENDED USE) PJ06-8142359	TITLE: CUSTOMER DRAWING PJ06-8142359 加长			
GENERAL TOLERANCE UNLESS OTHERWISE NOTED		APPD:	DWG NO.:			
		CHKD:	UNITS: mm SCALE: N/A SHEET: 1/1 REV: AO			
		DR:	3/9-16			